

DEFENDER[®]

Owner's Manual

Model:
Yamaha Rhino™

Caution:

Before using this product, read this manual and follow all Safety Instructions.



Yamaha Rhino Deluxe Cab Kit*

- Safety Instructions
- Cab kit Contents
- Hardware Assembly
- Panel Assembly
- Operation
- Replacement Parts

*DefenderCab™ cabs and accessories are in no way affiliated with Yamaha Rhino™. Any use of the name is only to identify their utility vehicle as it pertains to our accessories. Yamaha Rhino is a registered trademark of the Yamaha Motor Corporation™.

Warning: Failure to heed all safety and operating instructions and warnings regarding use of this product can result in serious bodily injury.

SAFETY INSTRUCTIONS

Read entire assembly instructions before beginning work.

Install all parts indicated in assembly instructions. Failure to fully assemble product before use could result in personal injury.

Assembly of product requires use of hand or power tools. If you are not experienced in using these types of tools, have product dealer do the install for you.

Some parts contain sharp edges as indicated in the manual. Wear protective gloves if necessary.

Dress for safety. DO NOT wear loose clothing, gloves, neckties or jewelry if using power tools to assemble this product.

Always keep your assembly area clean, uncluttered and well lit.

Keep visitors and children a safe distance away from the assembly area. Visitors should wear the same safety equipment described above.

Never operate your ATV with the cab doors open. Failure to properly latch the doors before moving the vehicle could result in serious injury.

CAB KIT CONTENTS

Your DefenderCab™ kit should contain the parts listed below. Separate all parts from packing materials. Do not discard packing material until assembly is complete. Item quantities are listed in parenthesis below.

Panels and Doors

- Roof Panel (x1)
- Rear Panel (x1)
- Windshield Panel (x1)
- Driver Side Panel (x1)
- Passenger Side Panel (x1)
- Driver Side Door (x1)
- Passenger Side Door (x1)
- Window for Door (x2)
- Driver Side Panel Bracket (x1)
- Passenger Side Panel Bracket (x1)
- Adjuster Plate (x4)
- Rubber Dust Shield (x1)
- Baton Strip (x1)

Hardware

- Hinges, Right Hand (x2)
- Hinges, Left Hand (x2)
- Striker Plates (x2)
- 10-32 x 1/2" Screws (x16)
- 10-32 Nylon Lock Nuts (x8)
- 1/4"-20 x 5/8" Screws (x58)
- 1/4"-20 Nylon Lock Nuts (x58)
- 1/4"-20 Heavy Duty Lock Nuts (x4)
- 1/4" Washers (x58)
- Self Tapping Screws (x6)
- Plastic Knobs (x10)
- Hard Gasket (1 Roll 25ft)
- Soft Gasket (1 Roll 25ft)
- Small Protective Trim (6ft) 

TOOLS REQUIRED FOR ASSEMBLY

Ensure that you have the following tools available before you begin the assembly of your DefenderCab™ kit. Note: Assembly requires two people.

- Phillips Screwdriver
- 1/2" Wrench
- 7/16" Wrench
- Electric drill
- 1/4" drill bit
- 5/32" drill bit
- Utility knife
- Wood clamps or Locking Pliers
- Rubber Mallet

HARDWARE ASSEMBLY

In this section, you will be instructed on how to pre-assemble all hardware onto the panels prior to the panel assembly.

1. Install Gaskets in Side Panels

a) Cut several 3" lengths of soft gasket and install as shown about every foot (12inches) around perimeter of side panel. Repeat for second panel.

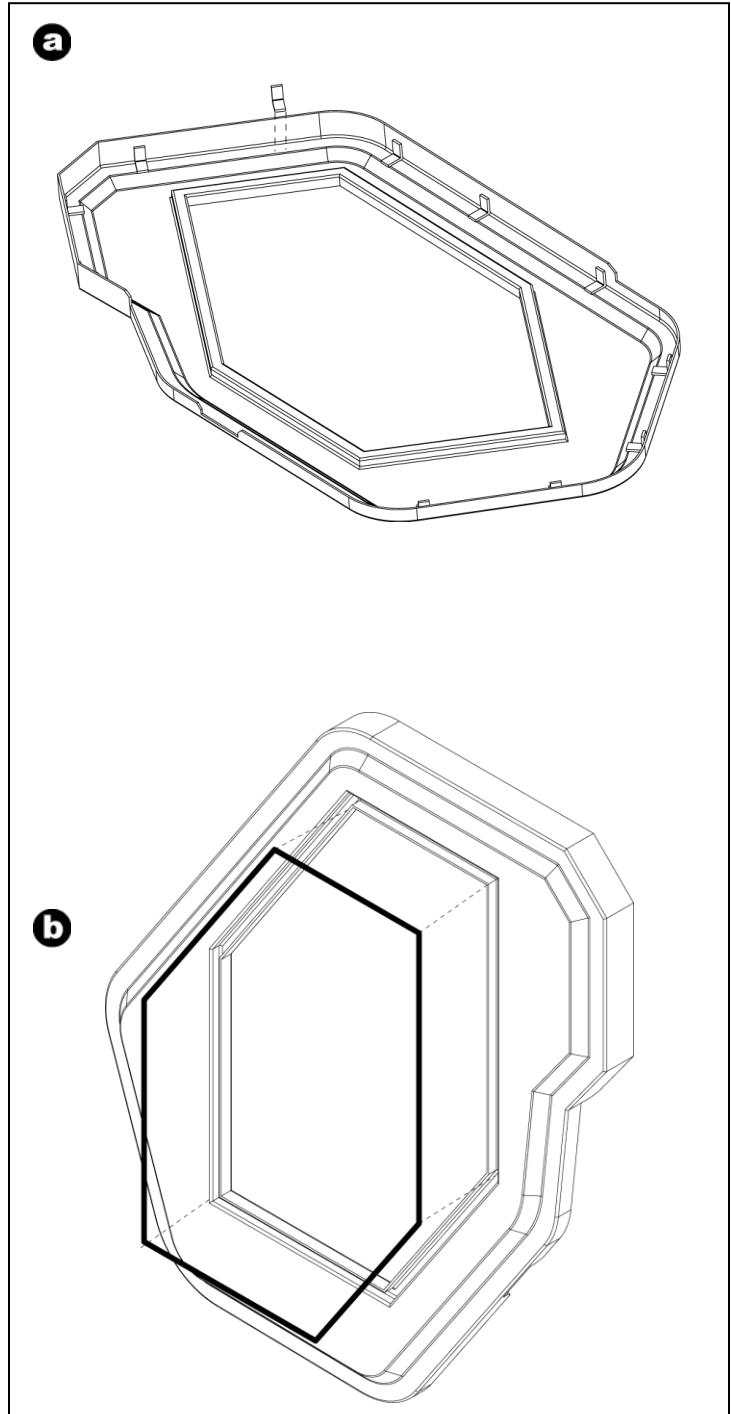

b) Install a length of soft gasket around perimeter of door opening in panel. Repeat for second panel.

2. Assemble Hinges

a) Install both hinge leaves with pins on driver side panel using four (4) 10-32 x 1/2" screws and a side panel bracket. Ensure hinges are oriented as shown in figure to the right.

a

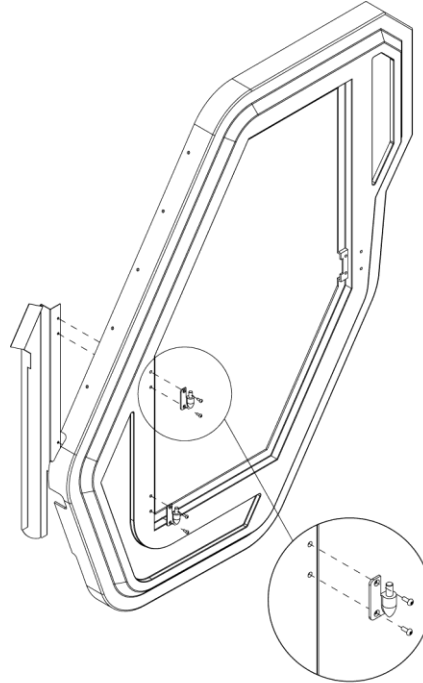

b) Install both hinge leaves with pins on passenger side panel using four (4) 10-32 x 1/2" screws and a side panel bracket. Ensure hinges are oriented as shown in figure to the right.

b

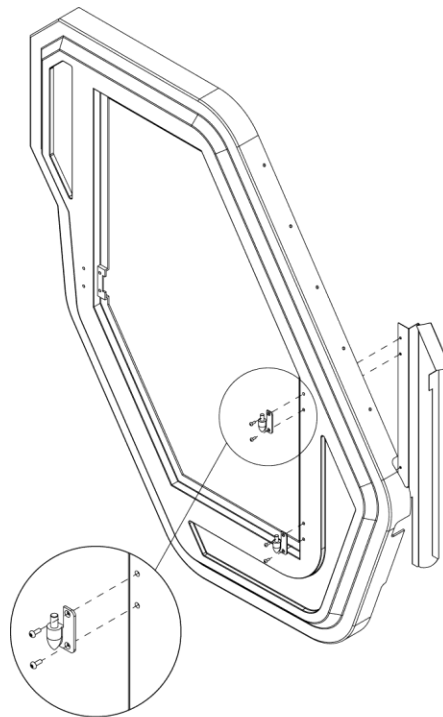

c) Install both hinge halves on driver side door using four (4) 10-32 x 1/2" screws, two (2) adjustment plates and one 1/4"-20 heavy duty lock nut. Insert (1) 1/4" Flat Washer between door and hinge as shown by arrow. Ensure hinges are oriented as shown in figure to the right.

NOTE: Only (1) washer is required per door.

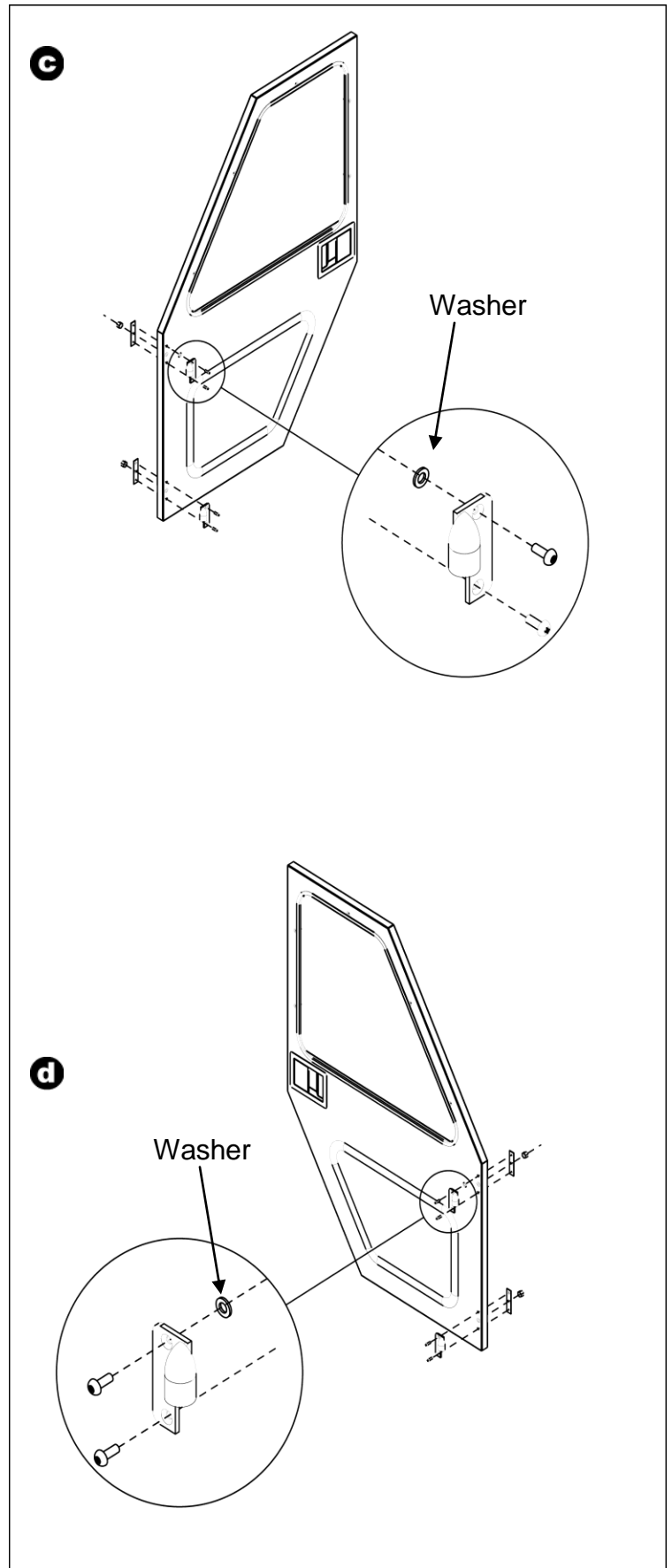

3. Install Striker Plates

a) Install striker plate on driver side panel using four (4) 1/4"-20 x 5/8" screws, four (4) 1/4"-20 nylon lock nuts and four (4) 1/4" washers. Note: Do not completely tighten screws. Striker plate will be adjusted in a following assembly step.

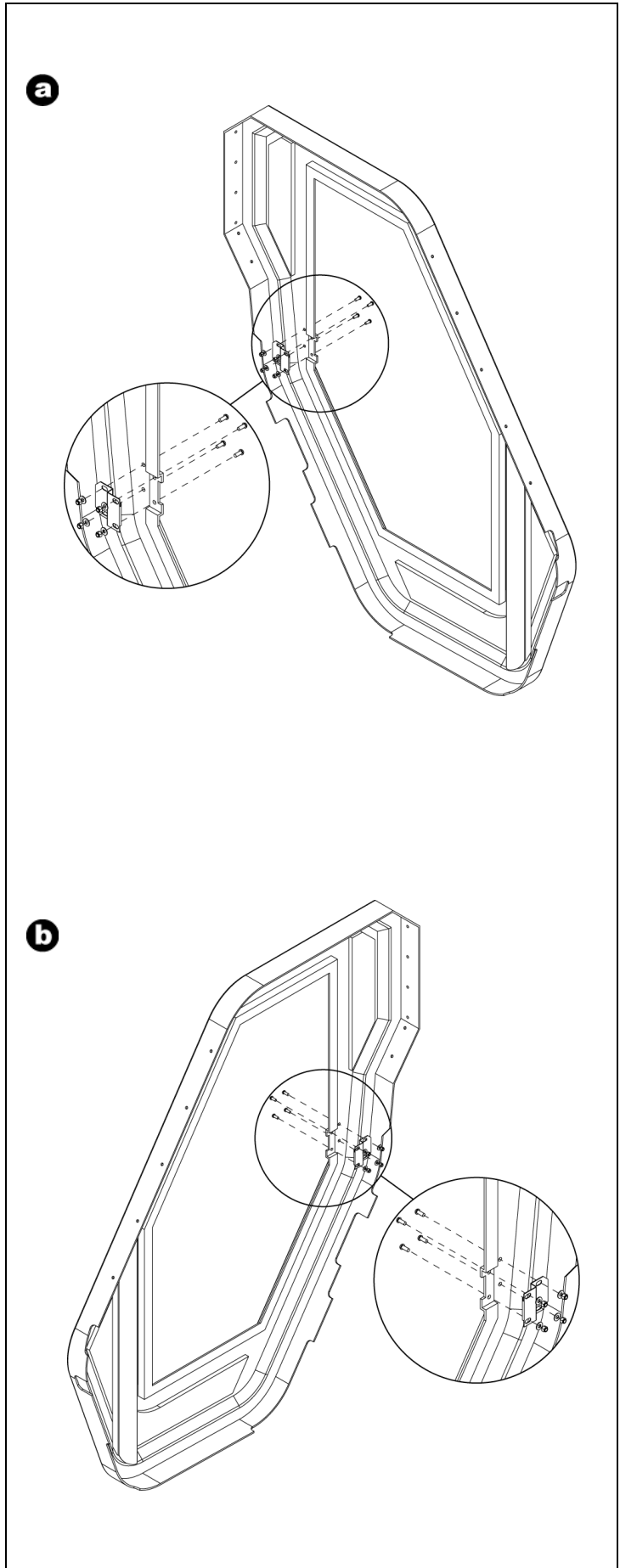

b) Install striker plate on passenger side panel using four (4) 1/4"-20 x 5/8" screws, four (4) 1/4"-20 nylon lock nuts and four (4) 1/4" washers. Note: Do not completely tighten screws. Striker plate will be adjusted in a following assembly step.

4. Pre-assemble Roof and Windshield Panel

a) Clamp the roof and windshield panel in the position shown on the right. Line up edge of roof panel with the bend line in the windshield panel.

b) Drill six (6) holes in the roof panel using the existing holes in the windshield panel as a guide. Use $\frac{1}{4}$ " drill bit to drill holes. (Not shown)

c) Assemble the roof panel and the windshield panel together using six (6) $\frac{1}{4}$ "-20 x $\frac{5}{8}$ " screws, six (6) $\frac{1}{4}$ " washers and six (6) $\frac{1}{4}$ "-20 nylon lock nuts.

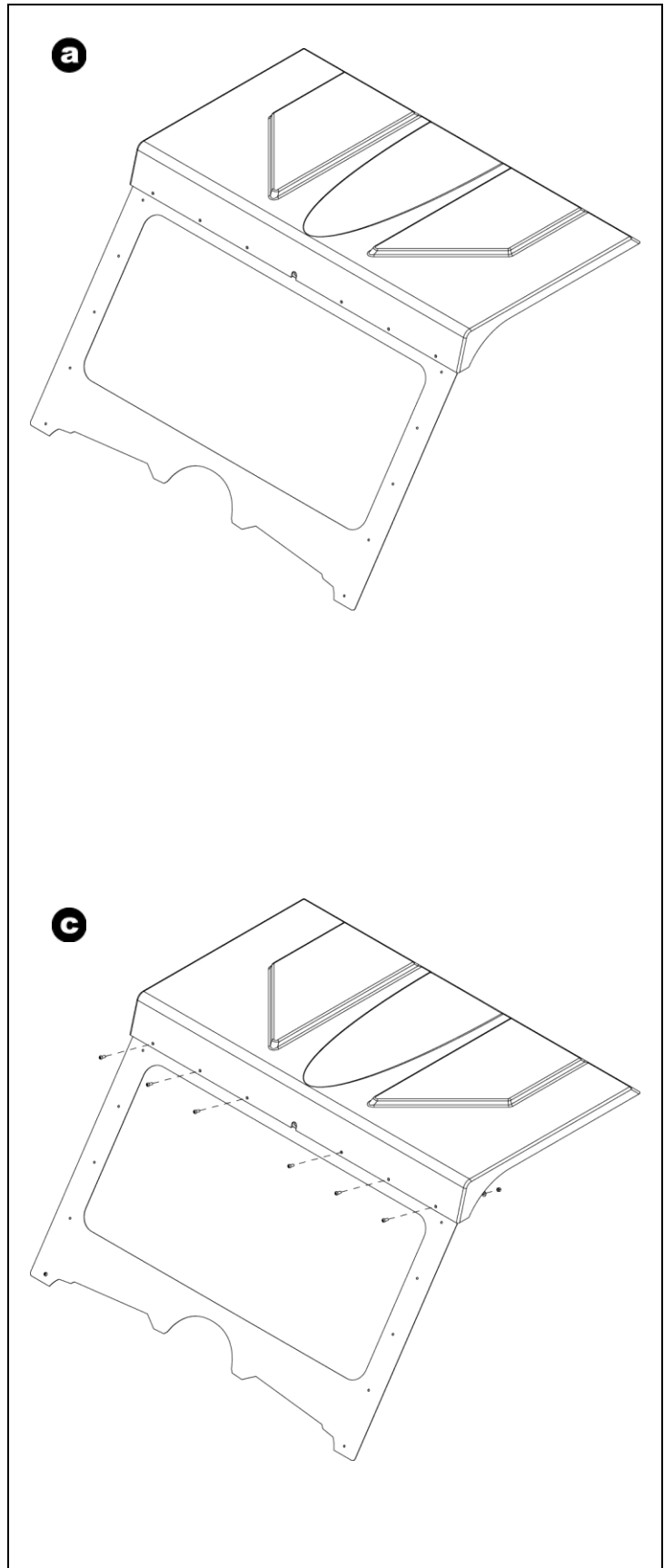

5. Install Protective Trim

a) Install small protective trim to bottom of windshield panel as shown. Cut from length of trim provided

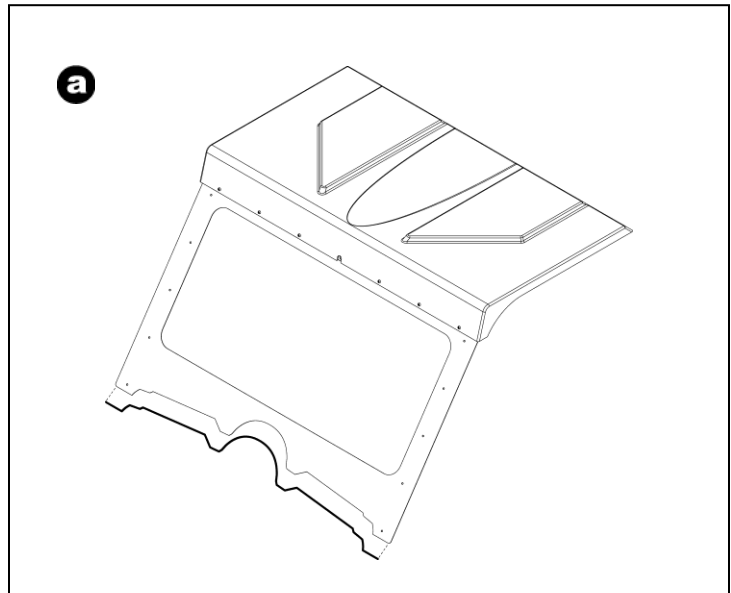

6. Pre-Assemble Dust Shield and Back Panel

a) Clamp back panel, rubber dust shield and baton strip together in position shown. Line up holes in baton strip with holes in back panel. Line up edge of rubber dust shield with edge of baton strip.

b) Drill seven (7) holes through the rubber dust shield using a $\frac{1}{4}$ " drill bit. (Not shown)

c) Assemble the back panel, dust shield and baton strip together using seven (7) $\frac{1}{4}$ "-20 x $\frac{5}{8}$ " screws, seven (7) $\frac{1}{4}$ " washers and seven (7) $\frac{1}{4}$ "-20 nylon lock nuts.

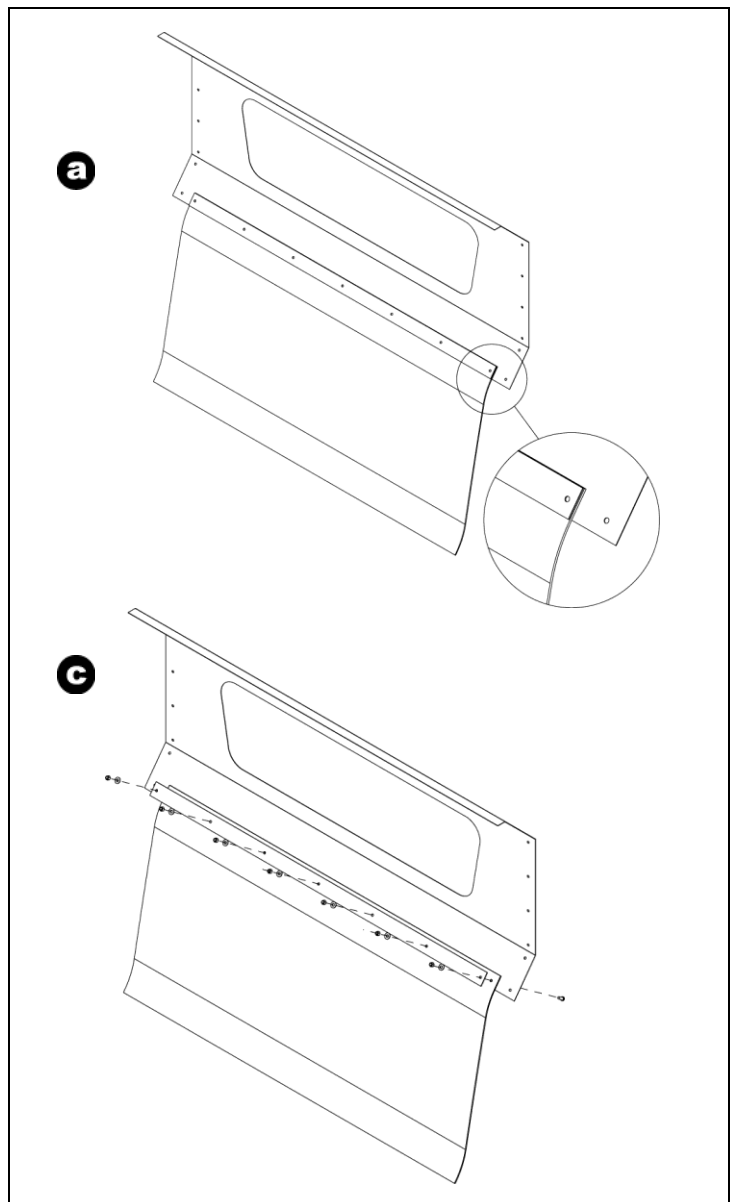

PANEL ASSEMBLY

7. Install Side and Back Panels

a) Install side panels in position shown on right and clamp tightly in place.

b) Install back panel/dust shield assembly in position shown on right and clamp tightly in place.

c) Drill sixteen (16) holes using $\frac{1}{4}$ " drill bit. Use existing holes in back panel as drill guide. (Not shown)

d) Assemble the back panel assembly and side panels using sixteen (16) $\frac{1}{4}$ "-20 x $\frac{5}{8}$ " screws, sixteen (16) $\frac{1}{4}$ " washers and sixteen (16) $\frac{1}{4}$ "-20 nylon lock nuts.

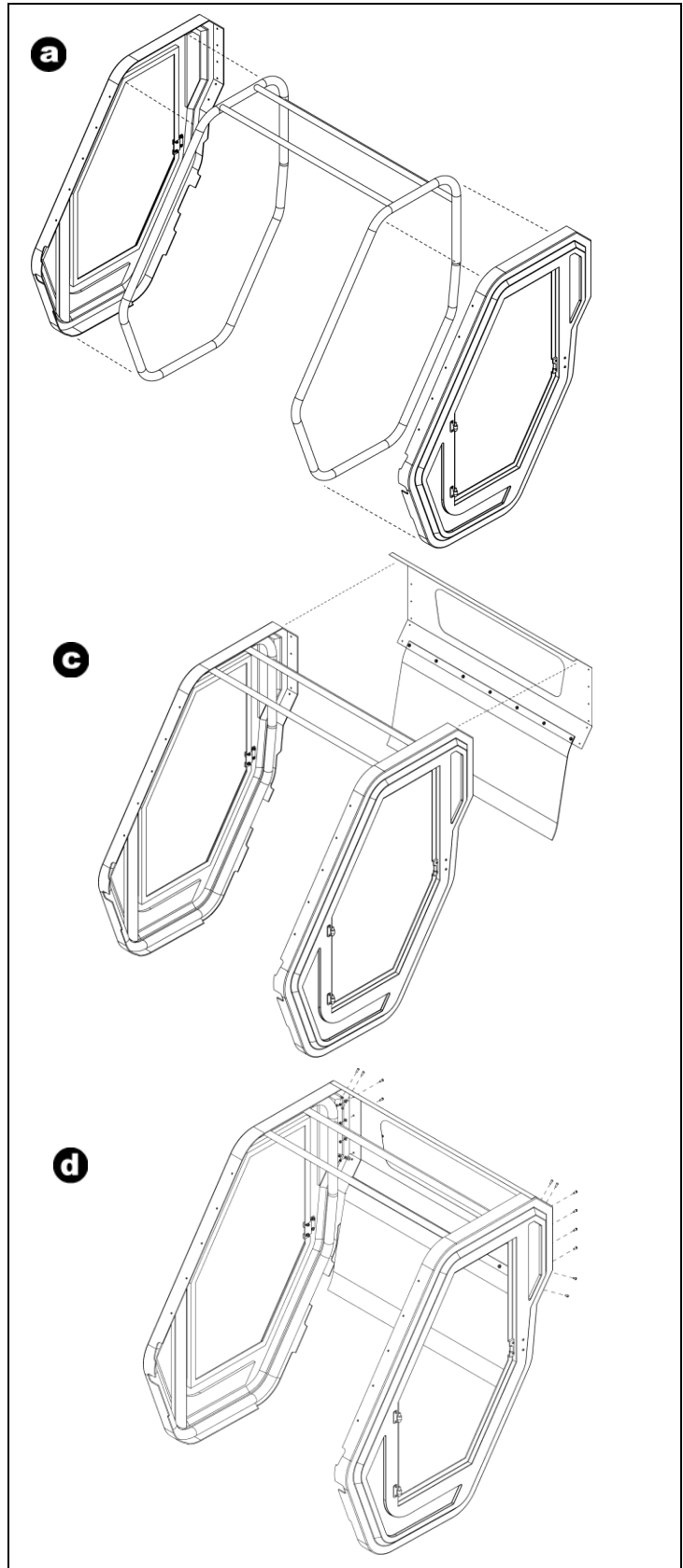

8. Install Roof Panel Assembly

a) Install roof assembly in position shown on right and clamp tightly in place.

NOTE: Cut and install a length of hard gasket on the hood of the Rhino ATV where the windshield panel contacts the plastic body panel. This will prevent scuffs marks on your Rhino body panel.

b) Drill seventeen (17) holes using $\frac{1}{4}$ " drill bit. Use existing holes in windshield and back panel as drill guide. (Not shown)

c) Assemble the roof panel assembly to the side panels using seventeen (17) $\frac{1}{4}$ "-20 x $\frac{5}{8}$ " screws, seventeen (17) $\frac{1}{4}$ " washers and seventeen (17) $\frac{1}{4}$ "-20 nylon lock nuts.

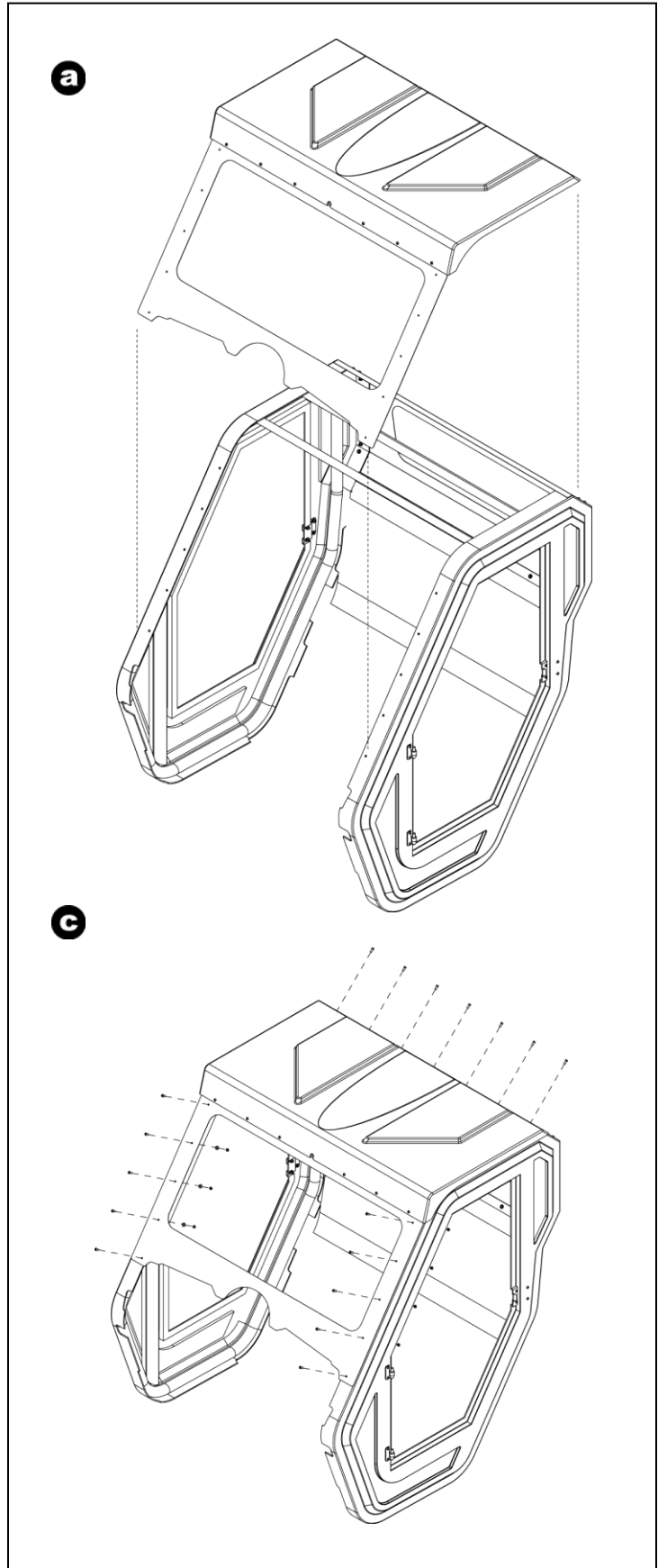

9. Secure Side Panels with Self-Tapping Screws (Optional Step)

Warning: Drilling holes in your Rhino roll bar could void your warranty. This step is not mandatory for proper function of your Rhino cab kit. It is however recommended for a Rhino that will see heavy duty usage.

a) Drill six (6) pilot holes using a 5/32" drill bit in approximate area shown. Drill through the plastic side panel into the roll bar.

b) Secure the side panels with six (6) self-tapping screws supplied. (Not shown)

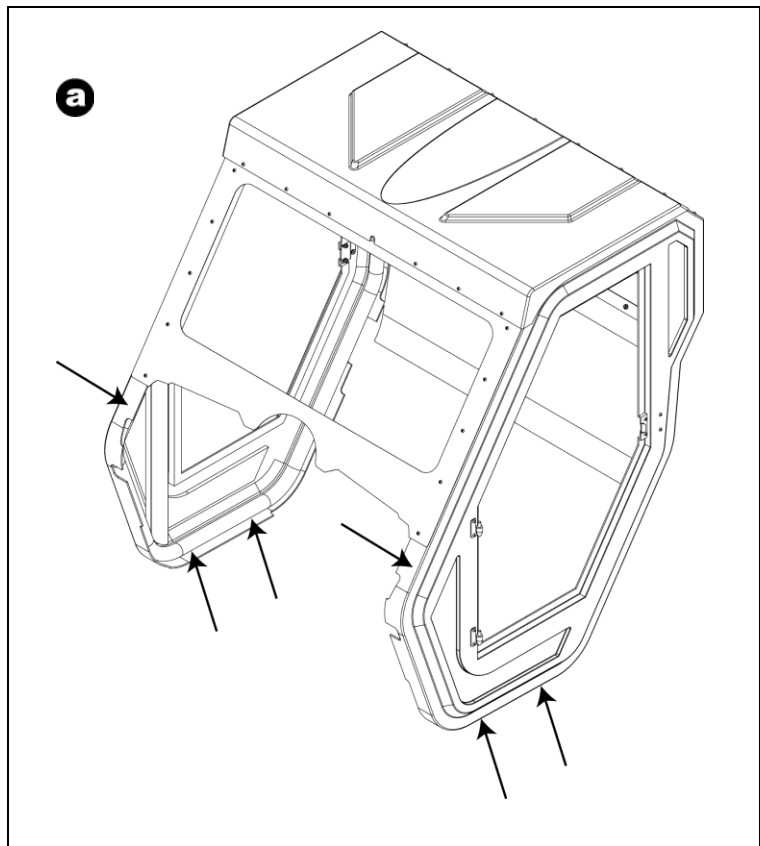

10. Install Doors

a) Install door as shown. Repeat procedure for other side.

b) Close door and tighten screws for striker plate. Test door for fit and function. If door does not latch properly, loosen and adjust striker plate. Repeat until door closes properly. (Not shown)

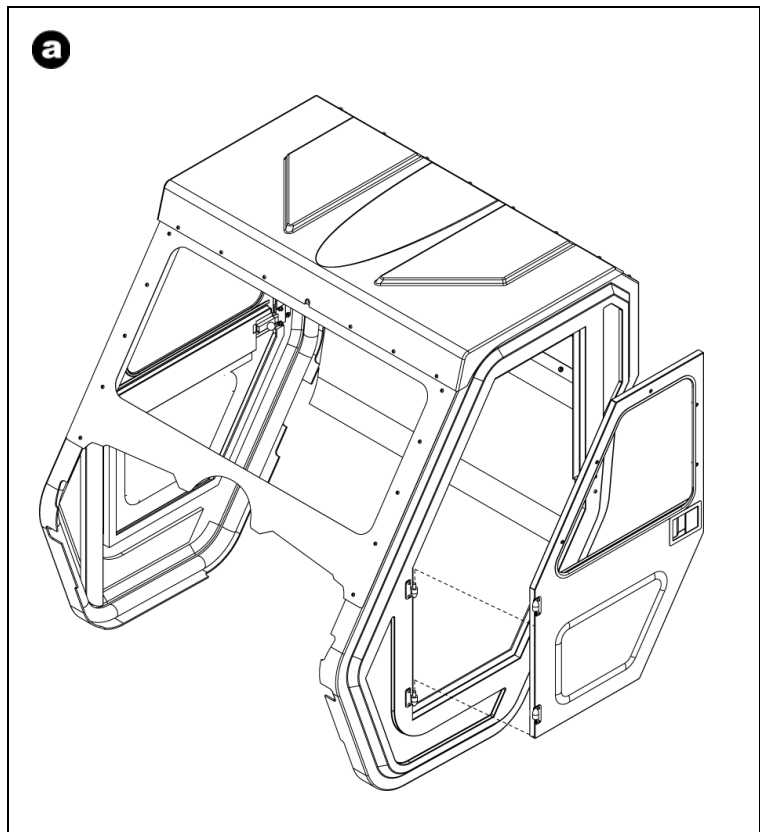

11. Install Windows in Doors

a) Install window in driver side door. Secure with five (5) plastic knobs provided.

b) Repeat procedure for passenger side door.

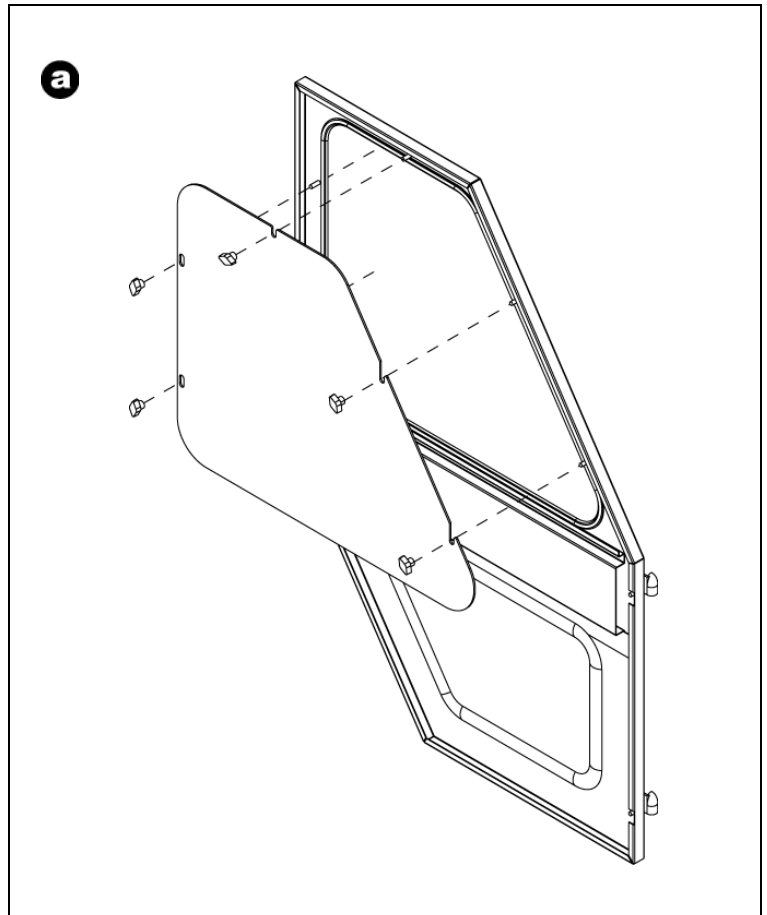

OPERATION

The DefenderCab™ with removable doors is very useful for work or play. It is perfect for the hunting, farming, fishing, commercial and recreational enthusiast. The cab and optional heater allow the full enjoyment of the Rhino in all weather conditions.

Removing the doors

In warm weather or to load your ATV on a trailer, the doors of your hard cab can be easily removed by opening the door and carefully lifting it off the hinges.

Cleaning your hard cab

Use same mild soap and techniques used to clean your ATV.

Removing the windows only

In warm weather, the windows of your cab can be removed to provide ventilation.

To order replacement parts, contact the Parts Department at:

LB Manufacturing Inc.
247 Arsenault Road,
Dieppe, N.B. Canada
E1A 7J5
Ph: (506) 388-9334 Fax (506) 388-3325
www.defendercab.com
parts@defendercab.com

Manual Revision: 2.2

Date: 26 October, 2012