

DEFENDER³

Owner's Manual

Model:
Yamaha Rhino™

Caution:

Before using this product, read this manual and follow all Safety Instructions.



Yamaha Rhino Roof/Windshield*

- Safety Instructions
- Cab kit Contents
- Hardware Assembly
- Panel Assembly
- Operation
- Replacement Parts

*DefenderCab™ cabs and accessories are in no way affiliated with Yamaha Rhino™. Any use of the name is only to identify their utility vehicle as it pertains to our accessories. Yamaha Rhino is a registered trademark of the Yamaha Motor Corporation™.

Warning: Failure to heed all safety and operating instructions and / or warnings regarding use of this product can result in serious bodily injury.

SAFETY INSTRUCTIONS

Read entire assembly instructions before beginning work.

Install all parts indicated in assembly instructions. Failure to fully assemble product before use could result in personal injury.

Assembly of product requires use of hand or power tools. If you are not experienced in using these types of tools, have product dealer do the installation for you.

Some parts contain sharp edges as indicated in the manual. Wear protective gloves if necessary.

Dress for safety. DO NOT wear loose clothing, gloves, neckties or jewelry if using power tools to assemble this product.

Always keep your assembly area clean, uncluttered and well lit.

Keep visitors and children a safe distance away from the assembly area. Visitors should wear the same safety equipment described above.

Roof / Windshield Kit Contents

Your DefenderCab™ Roof / Windshield kit should contain the parts listed below. Separate all parts from packing materials. Do not discard packing material until assembly is complete. Item quantities are listed in parenthesis below.

Panels

- (1) Plastic Roof Panel
- (1) Steel Windshield Panel

Hardware

- (1) 25ft Roll, High Density Foam Gasket
- (12 ft.) Small Edge Trim
- (6) Rubberized Clamp
- (1) 5/8" Black Plastic Hole Plug
- (6) 1/4" Black Plastic Hole Plug
- (6) #10-32 x 3/4" Screw
- (6) #10-32 Nyloc Nut
- (15) 1/4-20 x 3/4" Screw
- (15) 1/4-20 Nyloc Nut
- (15) 1/4" Nom. Flat Washer
- (4) 2 Hole Pipe Clamp

Tools Required for Assembly

Ensure that you have the following tools available before you begin the assembly of your DefenderCab™ Roof / Windshield kit. *****Note: Assembly May require an assistant*****

- Phillips & Flat Screwdrivers
- 7/16" Wrench / Socket
- Electric drill
- 1/4" drill bit
- Utility knife
- Dry erase marker

Kit Installation

1. Vehicle Preparation

i) Loosely install rubberized clamps onto roll cage at approximate locations shown in Fig.1. Ensure tabs are pointing towards the interior of the vehicle on the (6) windshield panel clamps. (Inset)

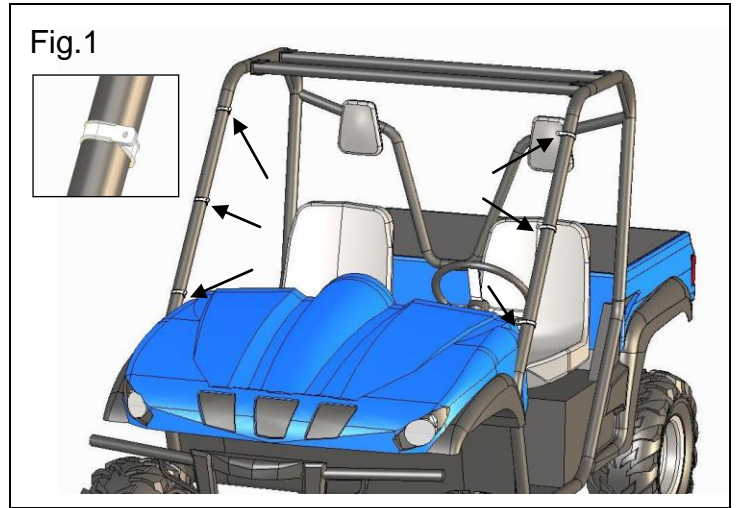

ii) Temporarily install windshield panel onto vehicle; ensure panel is level and aligned identically on both sides of vehicle. Use an erasable marker to transfer bottom edge of panel onto hood surface (Fig.2). Remove panel when done.

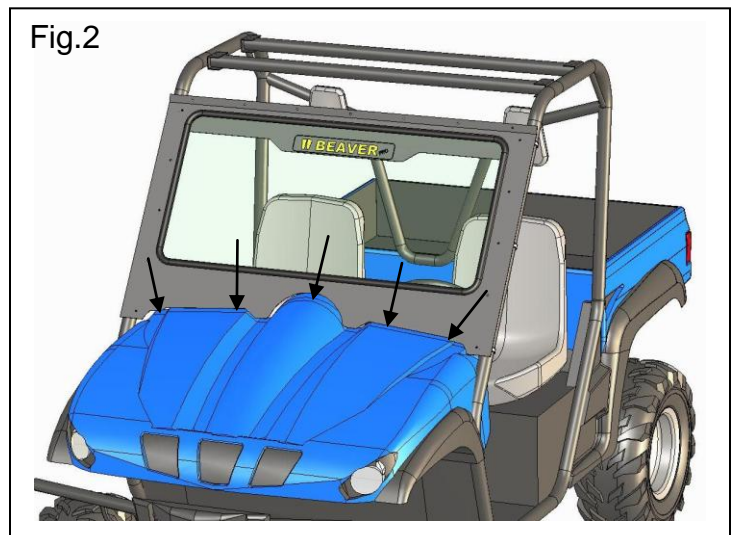

2. Installation

iii) Adhere high density foam gasket to top portion of hood using marker line as centerline guide to ensure windshield panel will sit squarely onto foam after installation. (Fig.3)

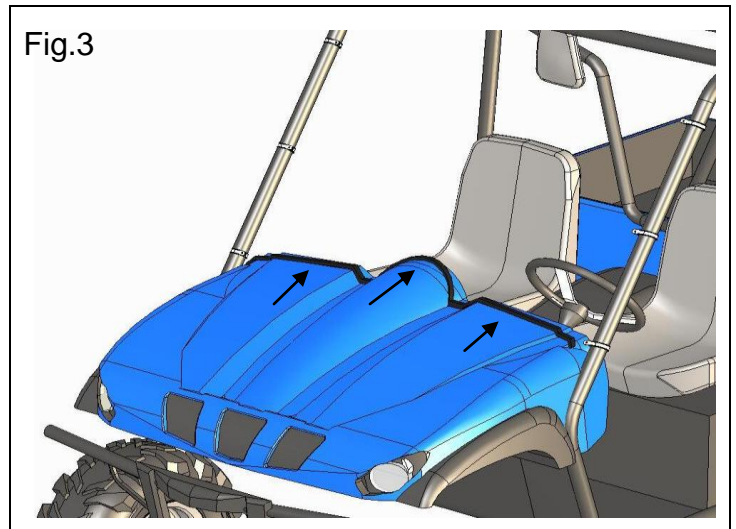

iv) Install small edgetrim onto sides and bottom of windshield panel. (Fig.4)

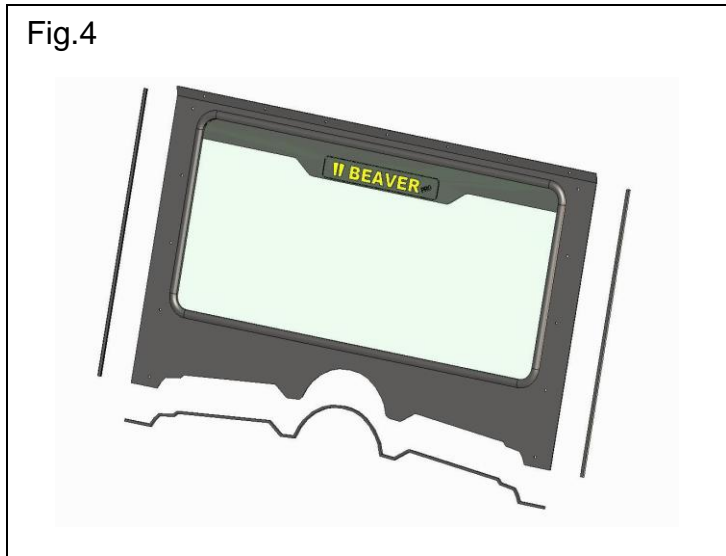

v) Re-install windshield panel onto vehicle. Fasten panel with (6) #10-32 x 3/4" Lg. screws and nyloc nuts (Fig.5) ensuring windshield panel sits firmly onto foam strip. Plug unused holes with provided 1/4" hole plugs.

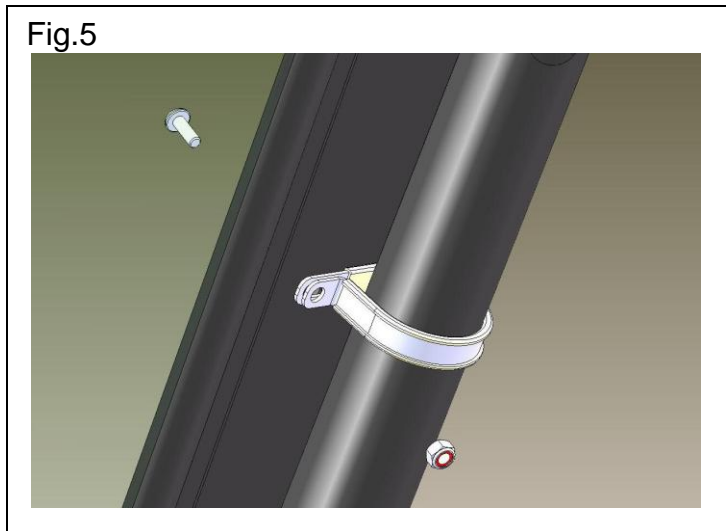

vi) Install and position roof panel onto vehicle allowing for equal spacing on either side of windshield panel edges. Once centered, **carefully** transfer upper windshield panel holes onto roof panel using a 1/4" drill bit. (Fig. 6)

NOTE: To prevent excessive rattling noise during operation, small foam strips can be used between roof and roll cage contact points at this time.

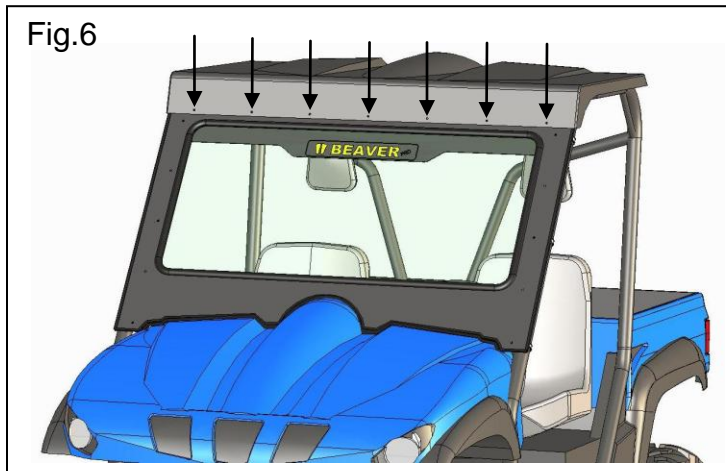

vii) Fasten roof panel to windshield panel using (7) 1/4-20 x 3/4" screws, washers and nyloc nuts (Fig.7).

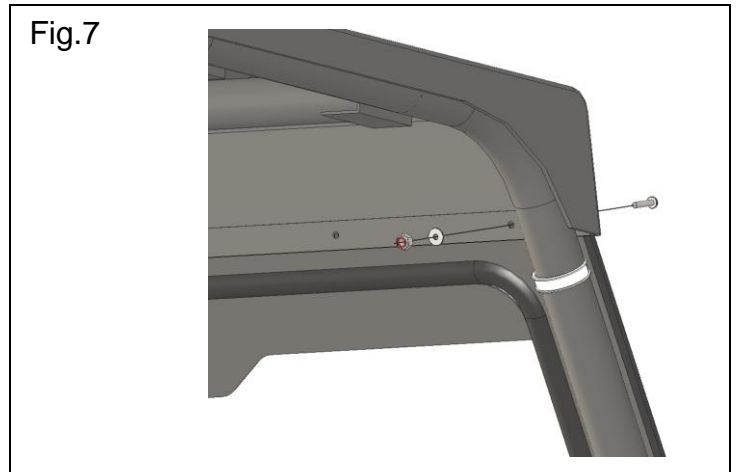

viii) Position roof clamps as desired and transfer clamp holes to roof panel using a 1/4" drill bit. (Fig. 8)

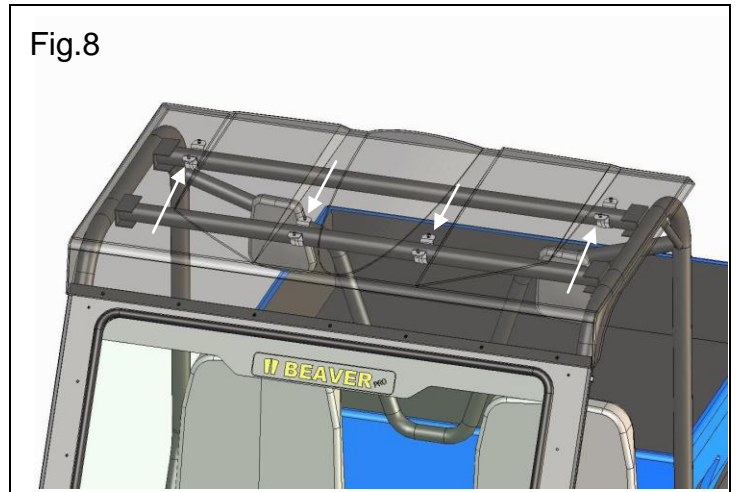

ix) Fasten roof panel to roll cage using (8) #1/4-20 x 3/4" screws, washer and nyloc nuts. NOTE: Install washer on roof top surface (Fig.9).

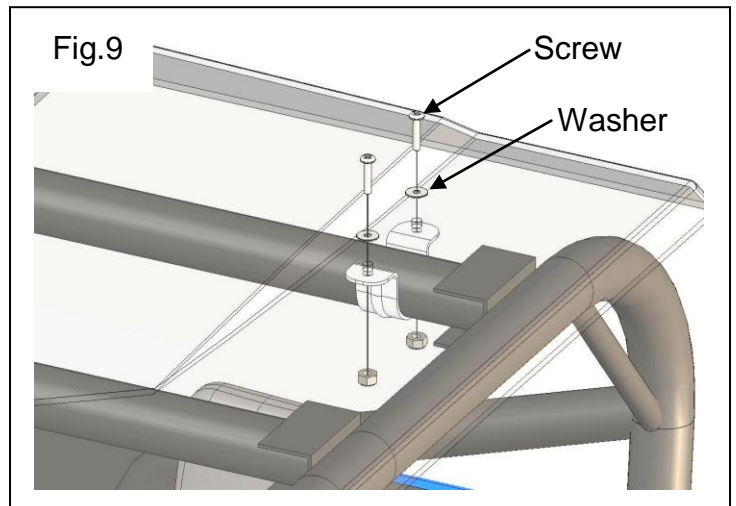

ix) If a Windshield Wiper Kit is not being installed, use remaining plastic hole plugs provided in kit to cover holes on upper portion of windshield panel.

Additional Notes:

- a) Wash enclosure as you would any other vehicle.

To order replacement parts, contact the Parts Department at:

LB Manufacturing Inc.
247 Arsenault Road,
Dieppe, N.B Canada
E1A 7J5
Ph: (506) 388-9334 Fax (506) 388-3325
www.defendercab.com
parts@defendercab.com

Manual Revision: 2.0

Date: 26 October, 2012